

# User Guide

## Industrial Actuator

Model: 01UP5



ACME



Ball Screw

### CAUTION

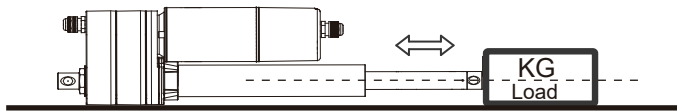

The load should be centered on the operating direction.

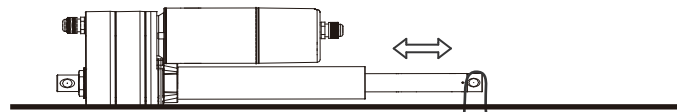

Side load is NOT good for actuators.

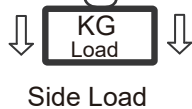

### WIRE CONNECTION

#### Power wire

For 01UP5 actuators, connection rule of power wires varies according to different types and gear ratio(s). Please follow the instructions below.

- Standard or With Potentiometer (POT) type

Gear ratio: 5:1 / 10:1 / 20:1



-When Red & White are connected to AC power, the actuator will extend; When Red & Black are connected to AC power, the actuator will retract.

Gear ratio: 30:1 / 40:1

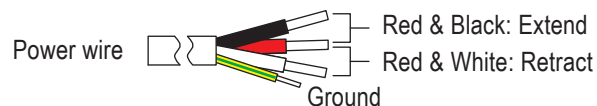

-When Red & Black are connected to AC power, the actuator will extend; When Red & White are connected to AC power, the actuator will retract.

- With Limit Switch (LT) type

Gear ratio: 5:1 / 10:1 / 20:1 / 30:1 / 40:1

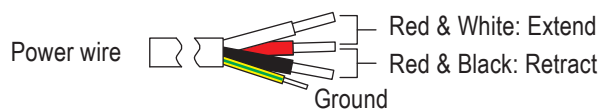

-When Red & White are connected to AC power, the actuator will extend; When Red & Black are connected to AC power, the actuator will retract.

### POT wire

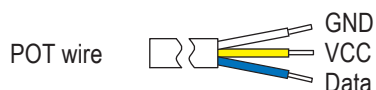

-White, Yellow & Blue are positioning signal wires.  
-The resistance between Blue and White wire increases when extending, and decreases when retracting.

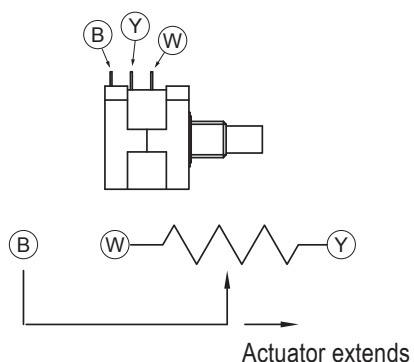

The POT value vs. stroke as shown in the table:

Stroke (mm)	Resistance ( $\pm 0.3K\Omega$ )
102	0.3 ~ 8.1K
153	0.3 ~ 8.7K
203	0.3 ~ 9.2K
254	0.3 ~ 7.4K
305	0.3 ~ 8.8K
457	0.3 ~ 9.4K
610	0.3 ~ 9.9K

### SAFETY DECLARATION

This appliance cannot be used by children or persons with reduced physical, sensory or mental capabilities, or lack of experience and knowledge, unless they have been given supervision or instruction.