

Product Data Sheet

Actuator 01KS3

01KS3 features its compact design, which is suitable for various applications that require limited installation space, such as window or gate opener, adjustable seat tilting and medical devices.



Features and Options

Main applications: Industrial, Furniture, Home care, Medical

Standard features:

- Input voltage: 12 / 24V DC
- Max. load: 1000N (Push / Pull)
- Max. static load: 2500N (Push / Pull)
- Speed at no load: 43.9mm/sec (Typical value)
- Speed at full load: 5.5mm/sec (Typical value @1000N loaded)
- Stroke: 50 / 100 / 150 / 200 / 250 / 300mm
- Noise level: Please refer to Performance Data
- IP level: IP54
- Preset limit switches
- Duty cycle: 25%, max. 1 min. continuous operation in 4 min.
- Operating ambient temperature: -25°C ~ +65°C
- Certified: CE Marking, Electromagnetic Compatibility Directive 2014/30/EU (for 01KS3 only)

Options:

- Medical version (01KS3M, compliance with EN 60601)
- Quiet version (01KS3Q, noise level ≤ 5 dB)
- Positioning signal feedback with Hall effect sensor x 1
- Positioning signal feedback with Hall effect sensor x 2
- Analog positioning feedback with Potentiometer (POT)
- IP level: IP65

Performance Data

Regular version (01KS3)

Model No.	Gear Ratio	Push / Pull Max. (N)	Self-locking force Max. (N)	* Typical Speed (mm/s)		* Typical Current (A)				Noise Level (dB)
				No Load	Full Load	No Load		Full Load		
						24V	12V	24V	12V	
01KS3-XX-05-K3...	5:1	150	2500	43.9	36.5	0.6	1.2	1.6	3.2	≤70
01KS3-XX-10-K3...	10:1	250	2500	27.6	23.5	0.6	1.2	1.6	3.2	≤70
01KS3-XX-20-K3...	20:1	500	2500	14.6	12.3	0.6	1.2	1.6	3.2	≤70
01KS3-XX-30-K3...	30:1	800	2500	9.5	7.5	0.6	1.2	1.6	3.2	≤70
01KS3-XX-40-K3...	40:1	1000	2500	7.0	5.5	0.6	1.2	1.6	3.2	≤70

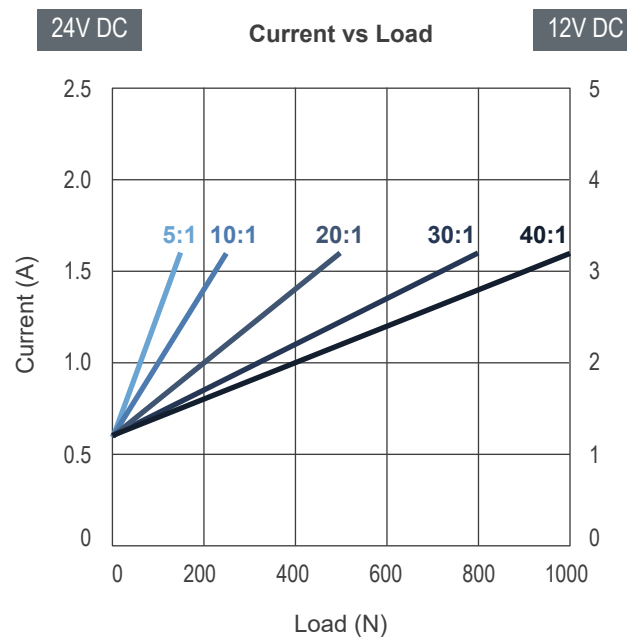
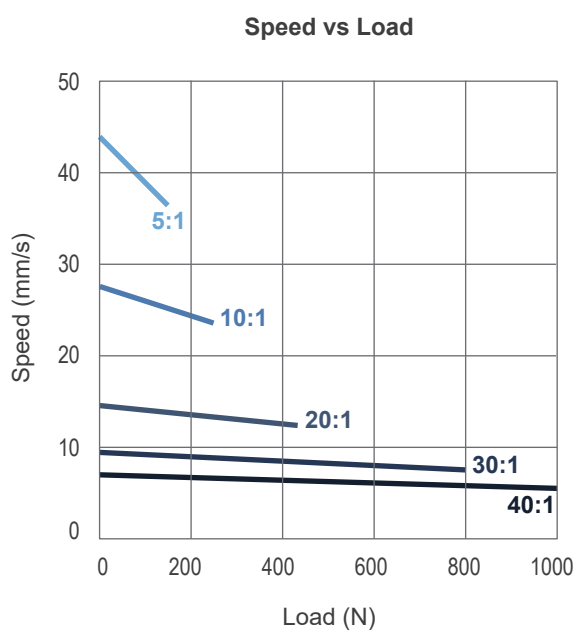

Remarks:

* The typical speed or typical current means the average value neither upper limit nor lower limit. The performance curves are made with typical values.

Medical version (01KS3M)

Model No.	Gear Ratio	Push / Pull Max. (N)	Self-locking force Max. (N)	* Typical Speed (mm/s)		* Typical Current (A) @24V DC		Noise Level (dB)
				No Load	Full Load	No Load	Full Load	
01KS3M-XX-05-K3 ..	5:1	150	2500	43.9	36.5	0.6	1.6	≦ 70
01KS3M-XX-10-K3 ..	10:1	250	2500	27.6	23.5	0.6	1.6	≦ 70
01KS3M-XX-20-K3 ..	20:1	500	2500	14.6	12.3	0.6	1.6	≦ 70
01KS3M-XX-30-K3 ..	30:1	800	2500	9.5	7.5	0.6	1.6	≦ 70
01KS3M-XX-40-K3 ..	40:1	1000	2500	7.0	5.5	0.6	1.6	≦ 70

Speed vs Load

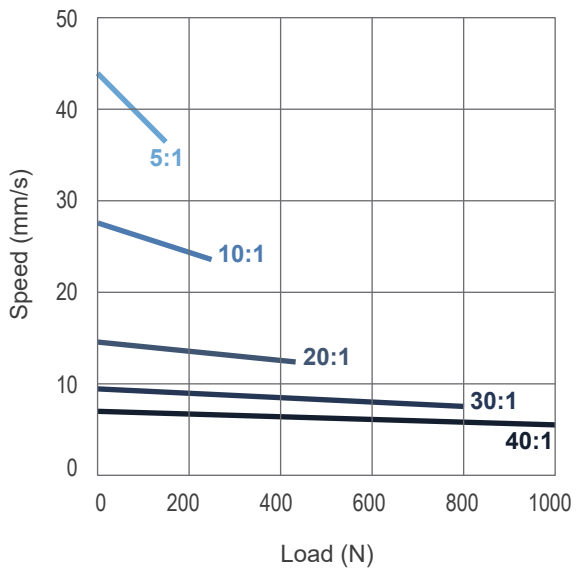

Current vs Load

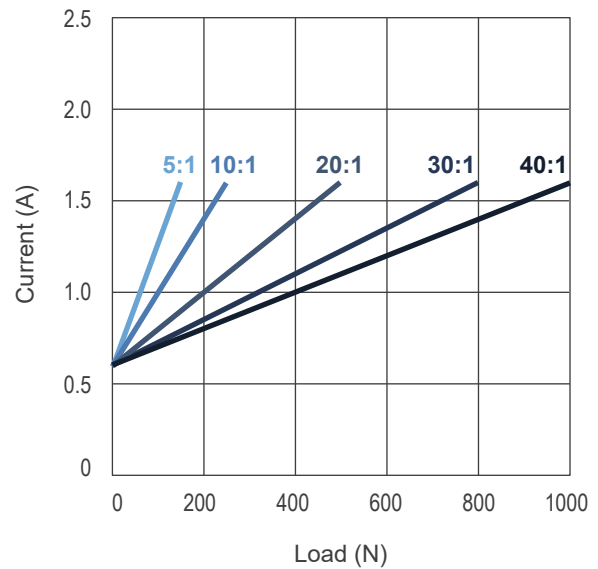

Remarks:

* The typical speed or typical current means the average value neither upper limit nor lower limit. The performance curves are made with typical values.

Quiet version (01KS3Q)

Model No.	Gear Ratio	Push / Pull Max. (N)	Self-locking force Max. (N)	* Typical Speed (mm/s)		* Typical Current (A)				Noise Level (dB)
				No Load	Full Load	No Load		Full Load		
						24V	12V	24V	12V	
01KS3Q-XX-20-D3..	20:1	500	2500	5.8	3.9	0.1	0.2	0.5	1.0	≤ 55
01KS3Q-XX-30-D3..	30:1	800	2500	3.8	2.6	0.1	0.2	0.6	1.2	≤ 55

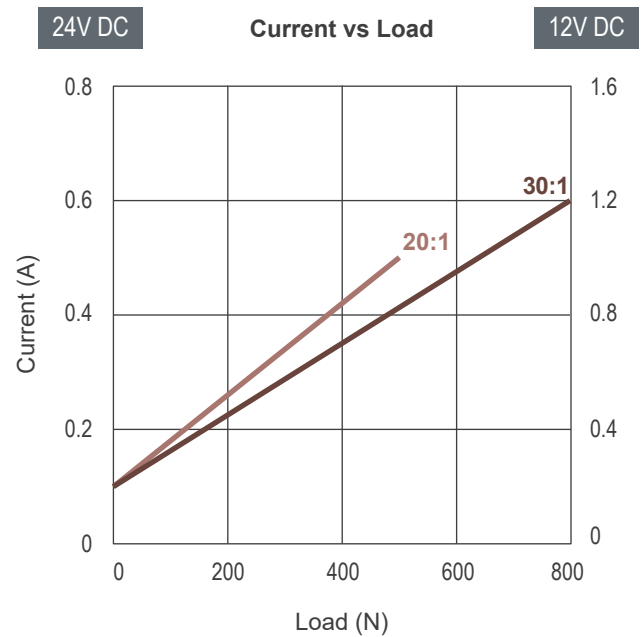
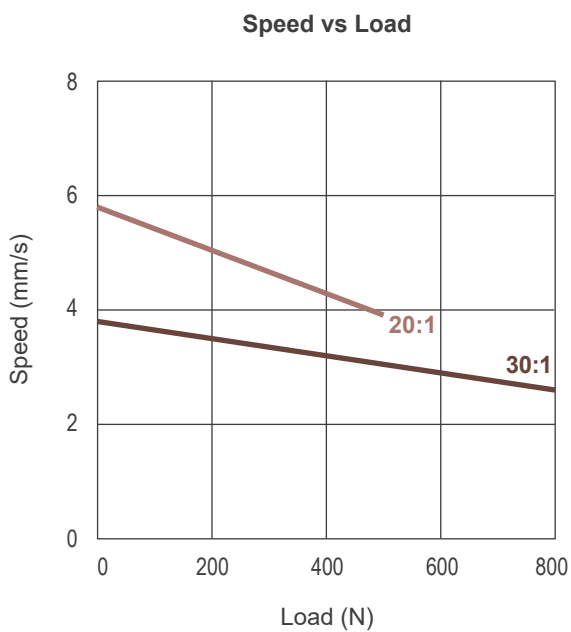

Remarks:

* The typical speed or typical current means the average value neither upper limit nor lower limit. The performance curves are made with typical values.

Dimensions

Retracted length (A)

Option	Front connector code	Stroke (S)					
		50	100	150	200	250	300
Basic or with Hall sensor	1	158	209	260	311	362	413
	3	199	250	301	352	403	454
	6	168.5	219.5	270.5	321.5	372.5	423.5
With POT	1	195	246	297	348	399	450
	3	236	287	338	389	440	491
	6	205.5	256.5	307.5	358.5	409.5	460.5

(tolerance: ±3mm)

Note: The dimension “A” is shown in page 5 & 6, as indicated in the figure below.

Drawing

- **Regular version (01KS3) & Quiet version (01KS3Q)**

- Basic, without positioning feedback.

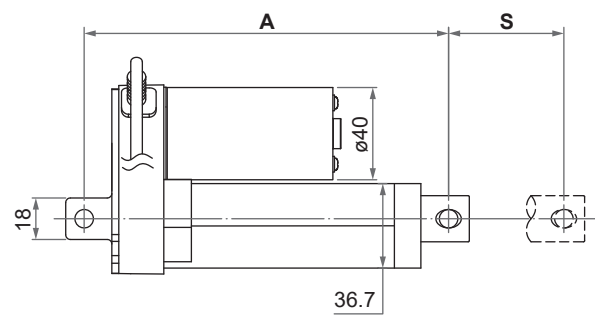
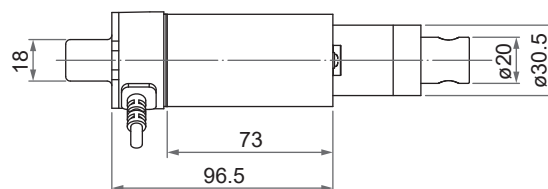
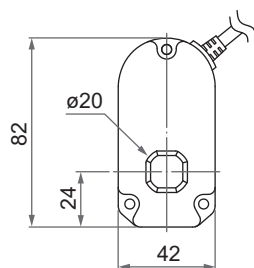

- With Hall effect sensor positioning feedback

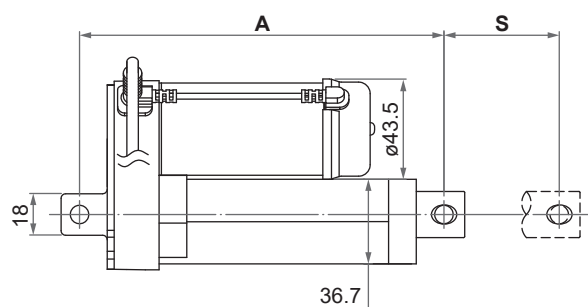
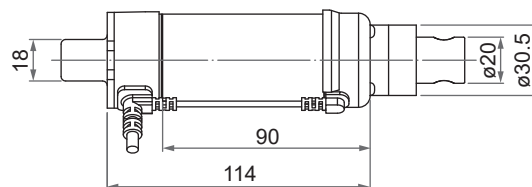
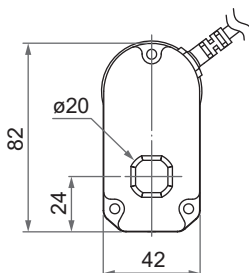

Note: As an example in 0° orientation for rear connector.

Unit: mm

- With potentiometer (POT) absolute positioning feedback

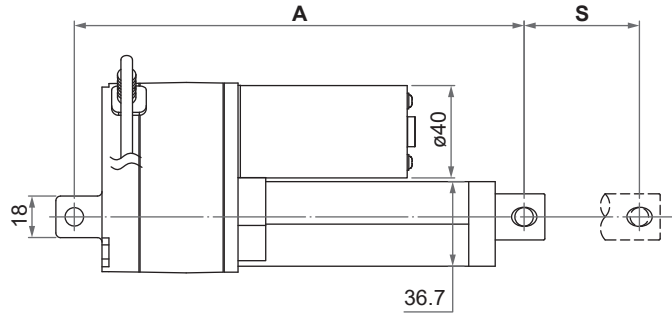
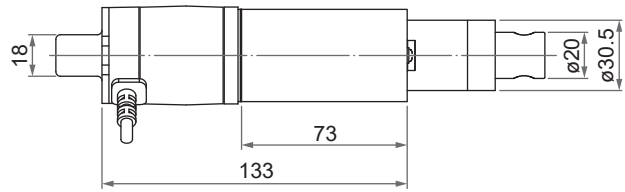
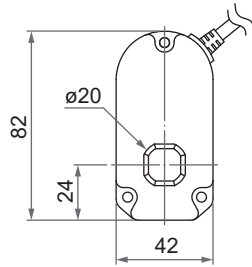

• **Medical version (01KS3M)**

- Basic, without positioning feedback

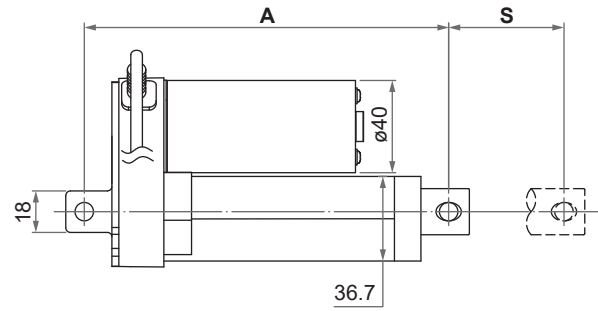
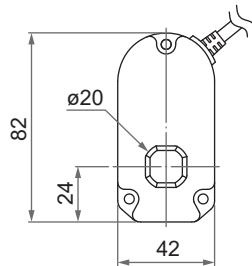
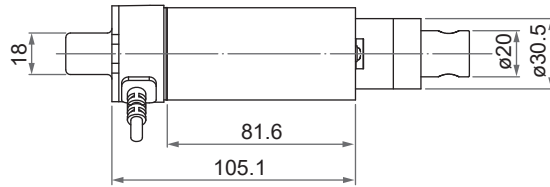

- With potentiometer (POT) absolute positioning feedback

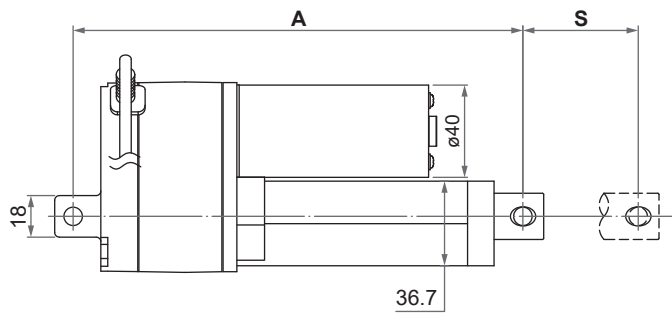
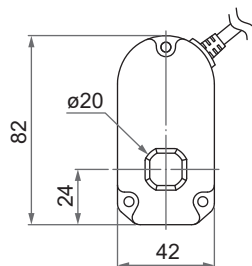
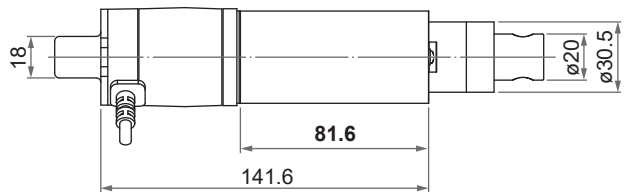

Note: As an example in 0° orientation for rear connector.

Unit: mm

• **Front connector**

1: Drilled hole

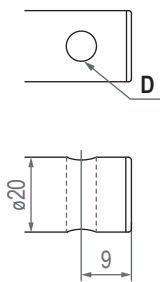

3: Spherical rod eye

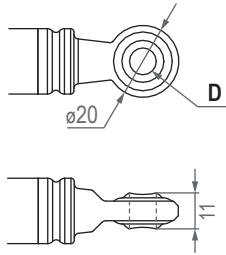

6: Plastic slot

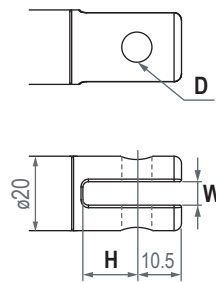

Front connector code	Diameter of pivot without bushing (D)	Slot width (W)	Slot depth (H)
1	ø6.4, ø8, ø10	N/A	N/A
3	ø8	N/A	N/A
6	ø8, ø10	6	15

• **Rear connector**

1: Zinc alloy clevis, 0°

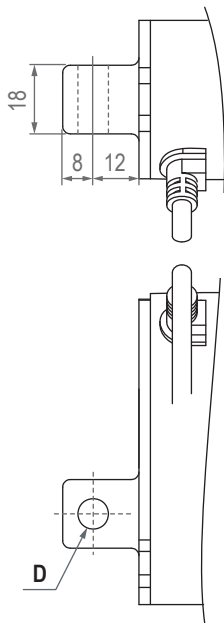

3: Zinc alloy clevis, 90°

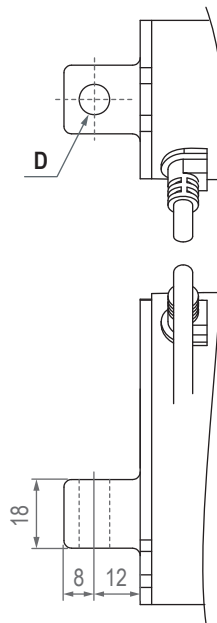

Rear connector code	Diameter of pivot without bushing (D)	Slot width (W)	Slot depth (H)
1, 3	ø6.4, ø8, ø10	N/A	N/A

Compatibility

Product	Model	01KS3 spec
Controller	01VO72	Standard
Accessory	01AN22 mounting bracket (Fig. 1)	Standard, mounting hole $\varnothing 6.4\text{mm}$, $\varnothing 8\text{mm}$ or $\varnothing 10\text{mm}$
	01V15 clamp (Fig. 2)	Comply with the section shape and size of the outer tube.



Fig. 1



Fig. 2

Wiring

- **Basic, without positioning feedback.**

	Wire color	Definition	Descriptions
Power wires	Red	DC power	Connect red wire to "Vdc +" & black wire to "Vdc -" of DC power to extend the actuators. Switch the polarity of DC input to retract it.
	Black		

- **With potentiometer (POT) absolute positioning feedback**

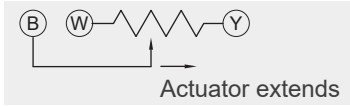
	Wire color	Definition	Descriptions														
Power wires	Red	DC power	Connect red wire to "Vdc +" & black wire to "Vdc -" of DC power to extend the actuators. Switch the polarity of DC input to retract it.														
	Black																
Signal wires	Yellow	Vin	Input voltage 70V max.														
	Blue	POT output	<p>1. Potentiometer specification:</p> <ul style="list-style-type: none"> - 10K ohm, 10 turns. - Tolerance $\pm 5\%$ <p>2. Output voltage: The voltage (resistance) between Blue and White increases linearly from about 0 when the actuators extend, and decreases when it retracts.</p>  <p>3. There are different resolutions according to the stroke length (as table below)</p> <table border="1" data-bbox="686 1265 1428 1568"> <thead> <tr> <th>Stroke</th> <th>Resistance (tolerance: $\pm 0.3K\Omega$)</th> </tr> </thead> <tbody> <tr> <td>50mm</td> <td>0.3 ~ 9.3K</td> </tr> <tr> <td>100mm</td> <td>0.3 ~ 9.7K</td> </tr> <tr> <td>150mm</td> <td>0.3 ~ 8.6K</td> </tr> <tr> <td>200mm</td> <td>0.3 ~ 9.6K</td> </tr> <tr> <td>250mm</td> <td>0.3 ~ 9.3K</td> </tr> <tr> <td>300mm</td> <td>0.3 ~ 9.3K</td> </tr> </tbody> </table>	Stroke	Resistance (tolerance: $\pm 0.3K\Omega$)	50mm	0.3 ~ 9.3K	100mm	0.3 ~ 9.7K	150mm	0.3 ~ 8.6K	200mm	0.3 ~ 9.6K	250mm	0.3 ~ 9.3K	300mm	0.3 ~ 9.3K
	Stroke	Resistance (tolerance: $\pm 0.3K\Omega$)															
50mm	0.3 ~ 9.3K																
100mm	0.3 ~ 9.7K																
150mm	0.3 ~ 8.6K																
200mm	0.3 ~ 9.6K																
250mm	0.3 ~ 9.3K																
300mm	0.3 ~ 9.3K																
White	GND																

• With single Hall effect sensor positioning feedback

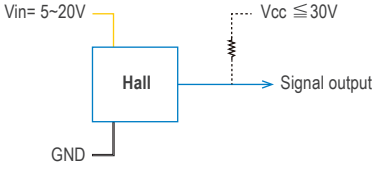
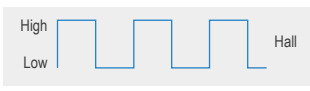
	Wire color	Definition	Descriptions												
Power wires	Red	DC power	Connect red wire to "Vdc +" & black wire to "Vdc -" of DC power to extend the actuator. Switch the polarity of DC input to retract it.												
	Black														
Signal wires	Yellow	Vin	Voltage input range: 5 ~ 20V												
	Blue	Hall output	<p>The signal wires output should connect the pull-up resistor to the operating voltage (Vcc) of the system. (10KΩ resistor is recommended)</p> <p>Wiring:</p>  <p>High= Determined by Vcc and the pull-up resistor. Low= GND</p> <p>Hall signal data:</p>  <p>Hall effect sensor resolution:</p> <table border="1"> <thead> <tr> <th>Gear ratio</th> <th>Resolution (pulses/mm)</th> </tr> </thead> <tbody> <tr> <td>5:1</td> <td>2.27</td> </tr> <tr> <td>10:1</td> <td>3.62</td> </tr> <tr> <td>20:1</td> <td>6.86</td> </tr> <tr> <td>30:1</td> <td>10.57</td> </tr> <tr> <td>40:1</td> <td>14.27</td> </tr> </tbody> </table>	Gear ratio	Resolution (pulses/mm)	5:1	2.27	10:1	3.62	20:1	6.86	30:1	10.57	40:1	14.27
	Gear ratio	Resolution (pulses/mm)													
5:1	2.27														
10:1	3.62														
20:1	6.86														
30:1	10.57														
40:1	14.27														
White	GND														

• With dual Hall effect sensors positioning feedback

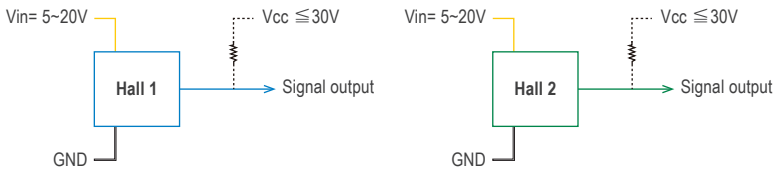
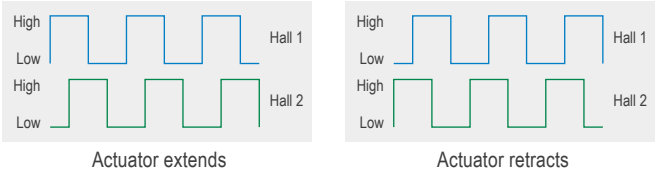
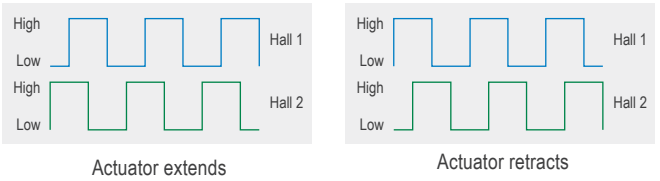
	Wire color	Definition	Descriptions																		
Power wires	Red	DC power	Connect red wire to "Vdc +" & black wire to "Vdc -" of DC power to extend the actuators. Switch the polarity of DC input to retract it.																		
	Black																				
Signal wires	Yellow	Vin	Voltage input range: 5 ~ 20V																		
	Blue	Hall 1 output	<p>The signal wires output should connect the pull-up resistor to the operating voltage (Vcc) of the system. (10KΩ resistor is recommended)</p> <p>Wiring:</p>  <p>High= Determined by Vcc and the pull-up resistor. Low= GND</p> <p>Hall signal data:</p> <p>- A type</p>  <p>- B type</p>  <p>Hall effect sensor resolution:</p> <table border="1"> <thead> <tr> <th>Gear ratio</th> <th>Resolution (pulses/mm)</th> <th>Hall signal data type</th> </tr> </thead> <tbody> <tr> <td>5:1</td> <td>2.27</td> <td>B type</td> </tr> <tr> <td>10:1</td> <td>3.62</td> <td>A type</td> </tr> <tr> <td>20:1</td> <td>6.86</td> <td>A type</td> </tr> <tr> <td>30:1</td> <td>10.57</td> <td>A type</td> </tr> <tr> <td>40:1</td> <td>14.27</td> <td>B type</td> </tr> </tbody> </table>	Gear ratio	Resolution (pulses/mm)	Hall signal data type	5:1	2.27	B type	10:1	3.62	A type	20:1	6.86	A type	30:1	10.57	A type	40:1	14.27	B type
	Gear ratio	Resolution (pulses/mm)	Hall signal data type																		
	5:1	2.27	B type																		
10:1	3.62	A type																			
20:1	6.86	A type																			
30:1	10.57	A type																			
40:1	14.27	B type																			
Green	Hall 2 output																				
	White	GND																			

Ordering Key

Regular version

01KS3- 24 - 05 - K3 - 150 - 1 1 D 4 0 3

Input voltage	12: 12V DC 24: 24V DC
Gear type	05: 5:1 10: 10:1 20: 20:1 30: 30:1 40: 40:1
Motor and Spindle type	K3: 6000rpm / 3mm pitch
Stroke	050: 50mm 100: 100mm 150: 150mm 200: 200mm 250: 250mm 300: 300mm
Front connector <i>(Refer to Page 7)</i>	1: Drilled hole 3: Spherical rod eye 6: Plastic slot
Rear connector <i>(Refer to Page 7)</i>	1: Zinc alloy clevis, 0° 3: Zinc alloy clevis, 90°
Positioning feedback	0: Basic, without positioning feedback. S: Hall effect sensor x 1 D: Hall effect sensor x 2 P: Potentiometer (POT)
IP level	4: IP54 (standard) 5: IP65
Reserved	0
Cable length	3: 900mm straight 5: 1500mm straight 6: 2000mm straight

Medical version

01KS3M- 24 - 05 - K3 - 150 - 1 1 P 4 0 3

Input voltage	24: 24V DC
Gear type	05: 5:1 10: 10:1 20: 20:1 30: 30:1 40: 40:1
Motor and Spindle type	K3: 6000rpm / 3mm pitch
Stroke	050: 50mm 100: 100mm 150: 150mm 200: 200mm 250: 250mm 300: 300mm
Front connector <i>(Refer to Page 7)</i>	1: Drilled hole 3: Spherical rod eye 6: Plastic slot
Rear connector <i>(Refer to Page 7)</i>	1: Zinc alloy clevis, 0° 3: Zinc alloy clevis, 90°
Positioning feedback	0: Basic, without positioning feedback. P: Potentiometer (POT)
IP level	4: IP54 (standard) 5: IP65
Reserved	0
Cable length	3: 900mm straight 5: 1500mm straight 6: 2000mm straight

Quiet version

01KS3Q- 24 - 20 - D3 - 150 - 1 1 D 4 0 3

Input voltage	12: 12V DC 24: 24V DC
Gear type	20: 20:1 30: 30:1
Motor and Spindle type	D3: 2400rpm / 3mm pitch
Stroke	050: 50mm 100: 100mm 150: 150mm 200: 200mm 250: 250mm 300: 300mm
Front connector <i>(Refer to Page 7)</i>	1: Drilled hole 3: Spherical rod eye 6: Plastic slot
Rear connector <i>(Refer to Page 7)</i>	1: Zinc alloy clevis, 0° 3: Zinc alloy clevis, 90°
Positioning feedback	0: Basic, without positioning feedback. S: Hall effect sensor x 1 D: Hall effect sensor x 2 P: Potentiometer (POT)
IP level	4: IP54 (standard) 5: IP65
Reserved	0
Cable length	3: 900mm straight 5: 1500mm straight 6: 2000mm straight

Certifications

Regular version

LD3 actuator is compliant with the following regulations, in terms of the essential conformity requirements of EMC Directive of 2014/30/EU.

Emission	Immunity
EN55014-1:2017+A11:2020	EN 55014-2:2015